



WAFER TYPE CHECK VALVE

Model: KVS - 100



SPECIFICATION

- Face to face dimension follow EN558-1 Series 50, DIN 3202
- Pressure Rating: PN16 / PN25
- Working Medium: Water
- Working temperature: -10...+120°C
- EPDM Seat, Stainless Steel Spring
- Flanged to BS 4504 / BS EN 1092
- ANSI standards available upon request



WAFER TYPE CHECK VALVE

Model: KVS - 100

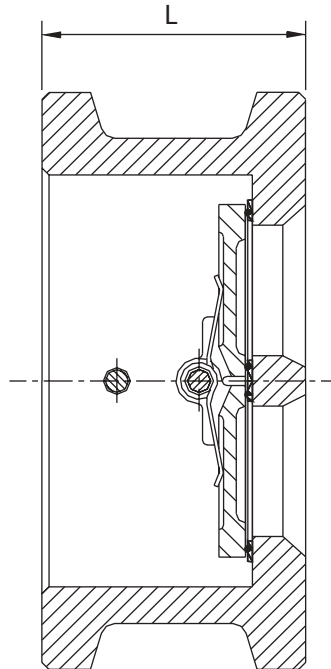

MATERIALS

Description	Material
Body	Cast Iron, Ductile Iron, Cast Steel
Shaft	Stainless Steel 316
Disc	DI Nickel Plated, SS304, SS316
Spring	SS316
Seat	EPDM

DIMENSIONS (mm)

Size	Inches	2"	2½"	3"	4"	5"	6"	8"	10"
	mm	50	65	80	100	125	150	200	250
L		43	46	64	64	70	76	89	114

Size	Inches	12"	14"	16"	18"	20"	24"	28"	32"
	mm	300	350	400	450	500	600	700	800
L		114	127	140	152	152	178	229	241