



LUGGED TYPE BUTTERFLY VALVE

Model: KVS - 310



SPECIFICATION

- Designed to BS 5155
- Pressure Rating: PN16 / PN25
- Working Medium: Water, Sea Water, Oil
- Working temperature: -10...+120°C
- Flanged to BS 4504 / BS EN1092
- Top flanges conforms to ISO 5211
- Lever operator (DN50-200), Gear operator (DN250-600)
- Optional chain wheel operator available
- Suitable with Electric / Pneumatic actuator

LUGGED TYPE BUTTERFLY VALVE

Model: KVS - 310

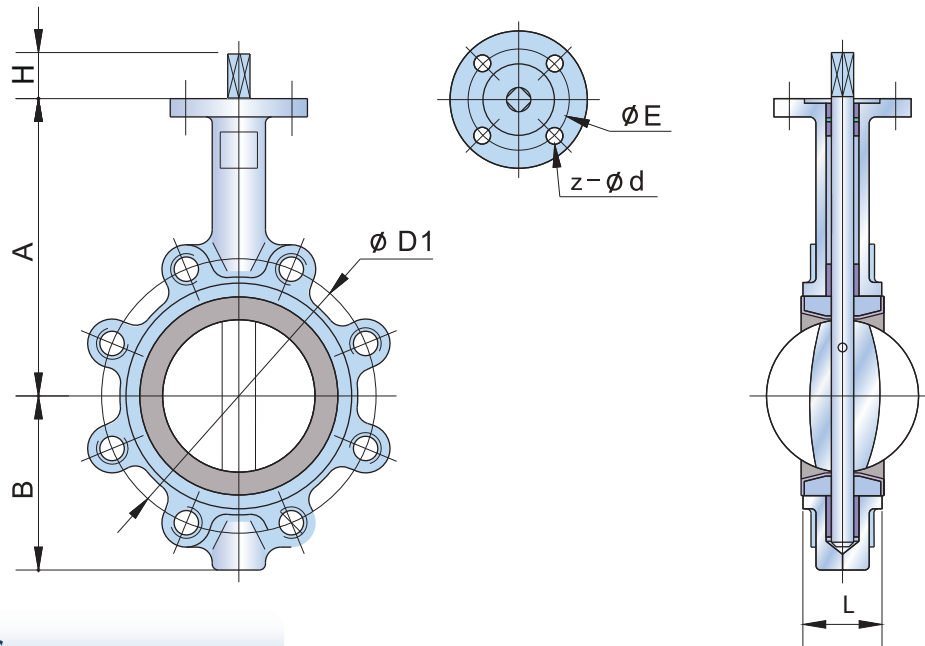

MATERIALS

Description	Material
Stem	Stainless Steel 410
Taper Pin	Stainless Steel 410
Disc	DI Nickel Plated/ Bronze/ SS304/ SS316
Seat	EPDM / NBR / FKM / PTFE
Body	Cast Iron / Ductile Iron /SS316
Gear	Cast Iron

DIMENSIONS (mm)

Size		A	B	L	H	E	z-d	D1
inches	mm							
2"	50	161	80	42	32	50	4-7	125
2½"	65	175	89	44	32	50	4-7	145
3"	80	181	95	45	32	50	4-7	160
4"	100	200	114	52	32	70	4-9	180
5"	125	213	127	54	32	70	4-9	210
6"	150	226	139	55	32	70	4-9	240
8"	200	260	175	60	45	102	4-12	295
10"	250	292	203	65	45	102	4-12	355
12"	300	337	242	76	45	102	4-12	410
14"	350	368	267	76	45	102	4-12	470
16"	400	400	309	86	51.2	140	4-18	525
18"	450	422	328	105	51.2	140	4-18	585
20"	500	480	361	131	64.2	140	4-18	650
24"	600	562	459	152	70.2	165	4-23	770